

# E-MORE 2M3S GS RD



Table frame, electric height adjustable with round lifting columns

- ✓ 2 motors / round 3-segment columns
- ✓ Five-language OLED control element with 4 memory slots and USB-C charging (18 W)
- ✓ Reminder function motivates the user to switch between sitting and standing Integrated
- ✓ Integrated double collision protection (sensitivity adjustable in 8 levels)
- ✓ GS approved, 5 years warranty, 4 colours



## Details

Motors	2
Lifting column segm.	3
Column cross-section	Ø70 mm
Lifting range	625-1275 mm
Frame width	1100-1800 mm
Table top size min	700x1100 mm
Table top size max	1000x2000 mm
Load capacity	120 kg
Memory keys	4
Display	OLED
USB charging	USB-C / 18 W
Speed	40 mm/s
Double Anti collision function	Overvoltage protection Gyroscope sensor
Reminder function	integrated
Child lock	integrated
Sound level	<50 dB
Power consumpt. min	0,1 W
Power consumpt. max	215 W
Duty cycle	max 2 min "on" / 18 min "off"
Cascading options	up to 12 columns

## Technical drawings

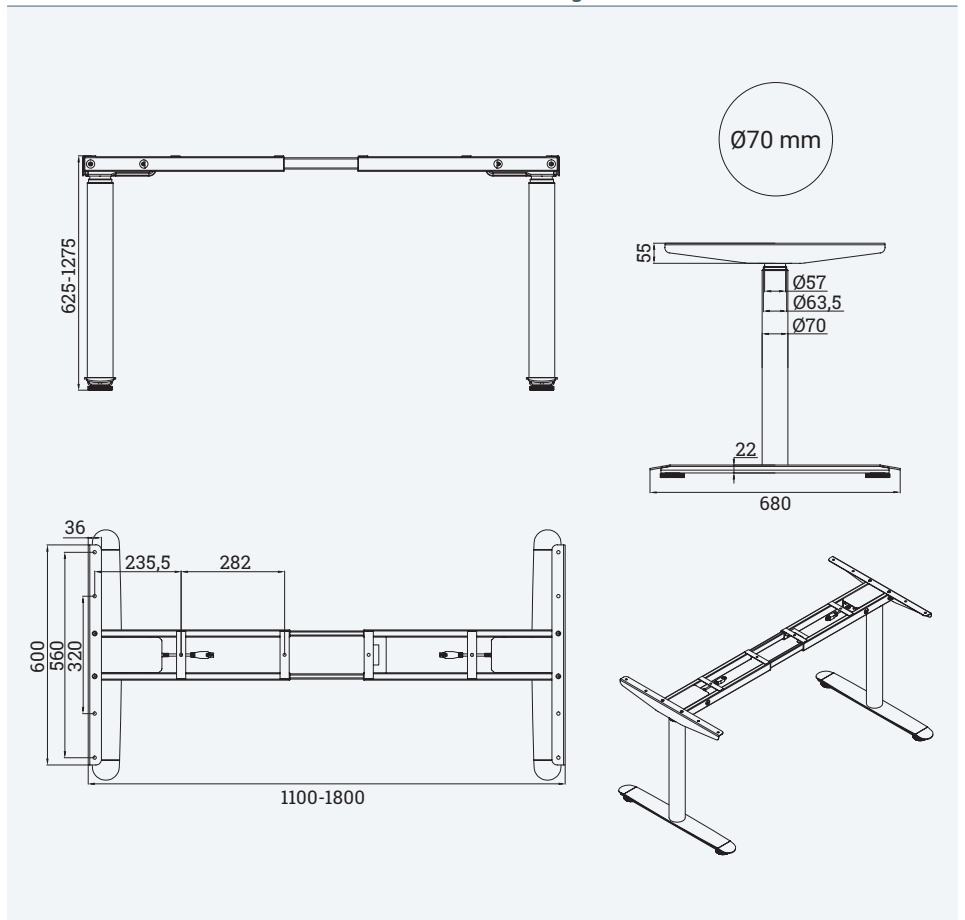

Article	Description	Colour	Item No.
E-MORE 2M3S GS RD	Electric height adjustable table frame, lifting column, Ø70 mm, 625-1275 mm, 2 motors, 3 segments, 120 kg, 40 mm/s	RAL 9017, Traffic black	301 132214
		RAL 7016, Anthracite grey	301 132221
		RAL 9006, White aluminium	301 132200
		RAL 9010, Pure white	301 132207

